

QuickPlate for 4-/5-/6-hole rims

Variable Flange Plates



Operating Instructions Product Overview

GEB 001 056

GB

Correct Use

The variable flange plate **QuickPlate** is used to mount a rim on a wheel balancer, exclusively as pressure plate in connection with a centering unit (e.g. DuoMatic, Centering sleeve *DuoExpert* or cone) and a wing or quick nut.

Any other use or changes of the product are not intended.

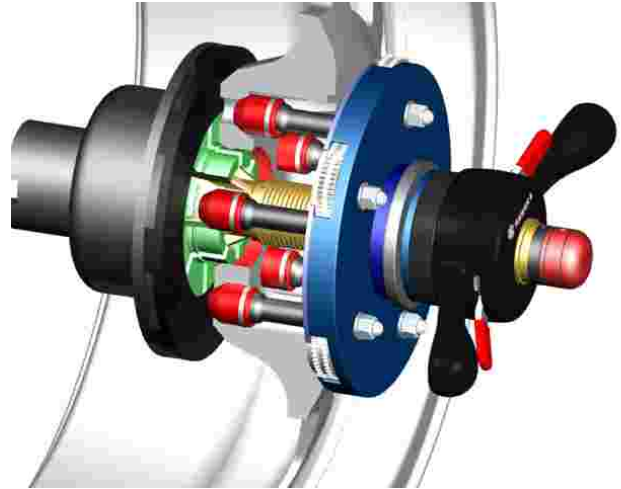

The variable flange plate **QuickPlate** must only be used on wheel balancers that are conform to the applicable safety regulations.



The manufacturer cannot be held responsible for any personal injury or material damage which is due to inappropriate use.

The variable flange plate **QuickPlate** can be used for 4-/5-/6-hole rims (depending on the version) and also for all passenger car and light truck (van) rims with a pitch circle diameter of 95 to 182 mm.



The variable flange plates **QuickPlate** are certified by the TÜV Nord and are subject to permanent quality control with regard to the manufacturing process.

Registration No. 78/780/552694A

Please note that the flange plate **QuickPlate** is part of a precision measuring system and must be always used and stored with a lot of care. This is also valid for the accessories.

How to use

Choice of the heads:

A important point for the perfect centering of the rim on the balancer is that the heads are fitting exactly in the hole of the bolt from the rim.
For various rim designs, you have to use various heads.

Basic diagram:

Type of rim	Type of bold head	color
Steel rim	rounded head	green
Alu rim	short taper	red
Alu rim with small bolt hole \emptyset	long taper	grey
SUV, Off-Road rim	Range-/ Land Rover	blue

Items of consignment of the 4-hole QuickPlate

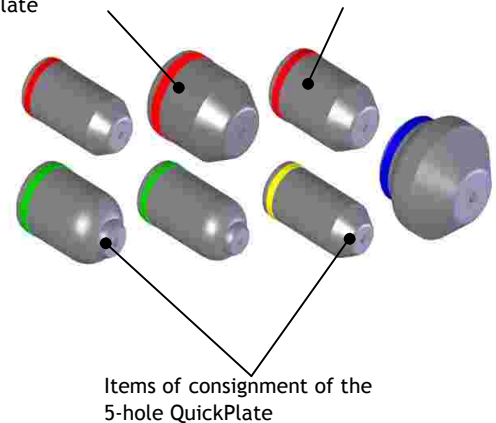

Attention

- Do not use various heads at the same time on a QuickPlate
- Use every time the QuickPlate with all heads (except 3-hole-rims). When it is not symmetric fully populated, you get wrong balancing results.

How to change the heads:

The heads can be changed very fast and easy.
With only one jerk, you can take the head out directly from the stud.

Please pay attention before fixing the head on the stud, that the **o-ring** and the **supporting spring** are on the right position.

Please press the bolt heads onto the studs, until they are engaged.



Please control always the right position of the bolt heads !

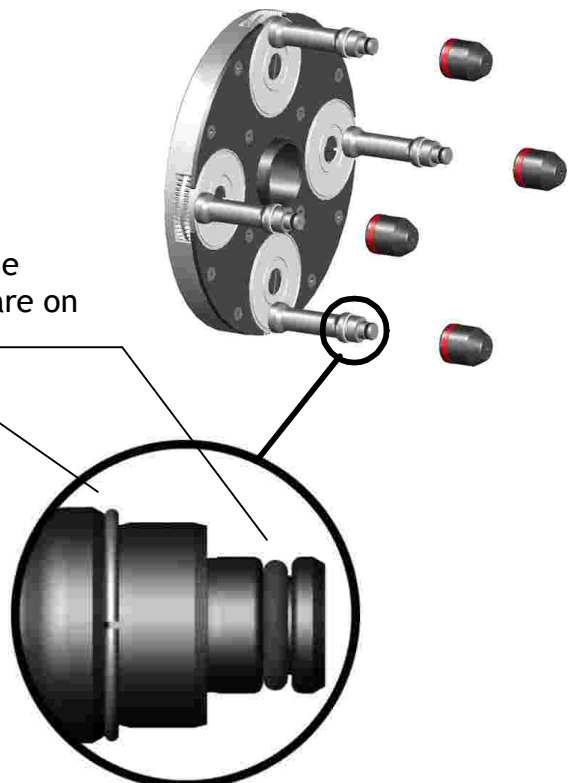

How to find the PCD (pitch circle diameter)

Please put the wheel horizontal on the ground. Now, turn the studs in this way, that they fix exactly into the holes of the bolts from the rim.

You fix the PCD with the ProLock System. Turn only the break-ring in the right direction.

 It is important to fix the PCD, because while mounting the wheel on the balancer, it can be put in the wrong place.

Please check the QuickPlate after fixing the PCD, that it fits exactly into the rim.

When it is necessary, repeat the course of event.

Now, the QuickPlate is in the position to mount the wheel on the balancer.

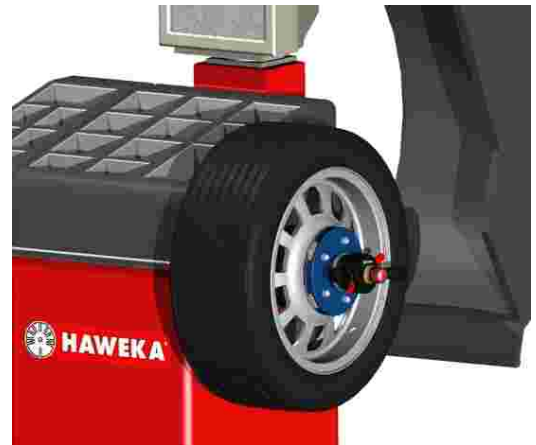

Optional Accessoires

Wallboard

Art.- No. 900 008 151
(Including in the QuickPlate set 200 456 xx5)

Bolt Heads

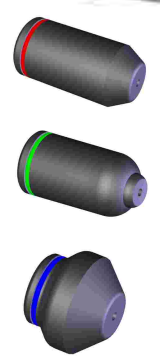
- | | | |
|-----------------------|--|---|
| Art.-No. 273e008 004 | short taper, 48 mm long, Ø 22,5 mm |  |
| Art.- No. 273e008 007 | rounded head, 48 mm long, Ø 24,5 mm | |
| Art.-No. 273e008 008 | Range- / Land Rover, 28 mm long, Ø 34,0 mm | |



HAWEKA AG Kokenhorststraße 4 ♦ 30938 Burgwedel ☎ 05139/8996-0 📠 05139/8996-222
www.haweke.com ♦ Info@haweke.com