

# Product

*info*



PI-Nr. MF0410051135-V2 Serie II

## World Innovation

## The Revolution in Wheel Balancing VARIABLE FLANGE PLATES



QuickPlate 5



QuickPlate 4



QuickPlate 6

- ⊗ Fully adjustable bolt circle (PCD) from 95 - 182 mm
- ⊗ For all 4-, 5- and 6-hole rims
- ⊗ No time-consuming search for the suitable bolt circle (PCD)
- ⊗ Changeable spring loaded bolt-heads for different rim types
- ⊗ Locking of the correct bolt circle (PCD) via the new ProLoc-System
- ⊗ Unbeatable in conjunction with the springless mid centering device „DuoExpert“ (see page 3)
- ⊗ HAWEKA Quality - Made in Germany

## QuickPlate

Part Numbers:

Set of QuickPlates: 200 456 xx5

QuickPlate 4-holes 249 009 xx0

QuickPlate 5-holes 259 009 xx0

QuickPlate 6-holes 269 009 xx0

Wall Board 900 008 151

Enter diameter of the balancer shaft in mm as 7th and 8th digits: (28, 30, 35,36,38,40)

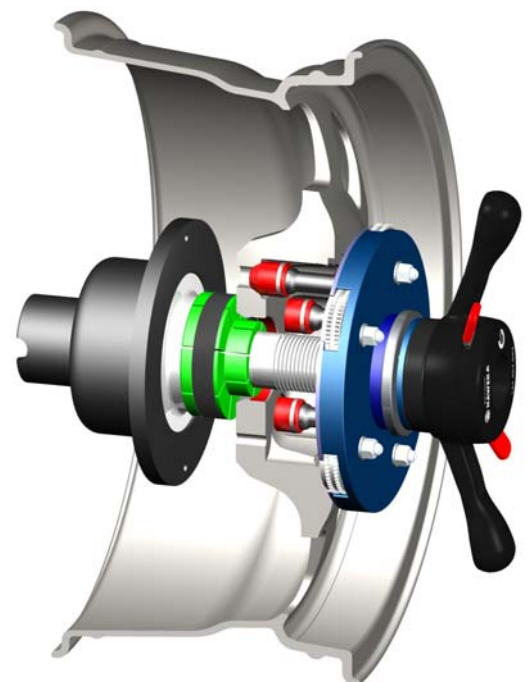

# QuickPlate 4

Part Number: 249 009 xx0



## head - Options





<b>Standard</b> (enclosed)		<b>273e008 002</b> head length: 28 mm Short taper Ø 24,5 mm
<b>Option I</b>		<b>273e008 004</b> head length: 48 mm Short taper Ø 24,5 mm
<b>Option II</b>		<b>273e008 011</b> head length: 48 mm Long taper Ø 22,5 mm

# QuickPlate 5

Part Number: 259 009 xx0

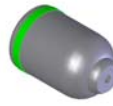

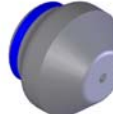

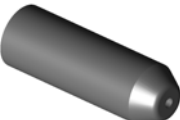

## head - Options

<b>Standard:</b> (enclosed)		<b>273e008 011</b> head length: 48 mm Long taper Ø 22,5 mm
<b>Standard:</b> (enclosed)		<b>273e008 006</b> head length: 38 mm Round head Ø 24,5 mm
<b>Option I</b>		<b>273e008 004</b> head length: 48 mm Short taper Ø 24,5 mm
<b>Option II</b>		<b>273e008 008</b> head length: 28 mm Range- / Land Rover Ø 34,0 mm
<b>Option III</b>		<b>273e 008 007</b> head length: 48 mm Round head Ø 24,5 mm
<b>Option IV</b>		<b>273e 008 023</b> head length: 55,6 mm Long taper Ø 19,0 mm



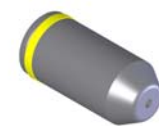



# QuickPlate 6







Part Number: 269 009 xx0

	<b>head - Options</b>		
	<b>Standard:</b> (enclosed)		<b>273e008 003</b>  head length: 38 mm Short taper Ø 24,5 mm
	<b>Option I</b>		<b>273e008 011</b>  head length: 48 mm Long taper Ø 22,5 mm
<b>Option II</b>		<b>273e008 025</b>  head length: 58 mm Long taper Ø 22,5 mm	

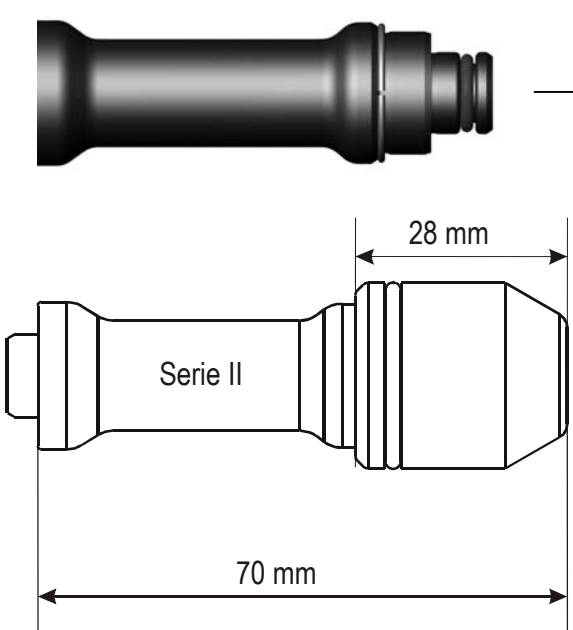
## Centering System „DuoExpert“ (Part.-No. 164 400 500)

\*\*\* available for all shaft diameters \*\*\*

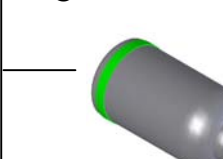
	Tolerance-free balancing with little wear		
	Approvals from leading car manufacturers		
	Virtually zero remount errors		
	Simple to use		
	HAWEKA Quality - Made in Germany		

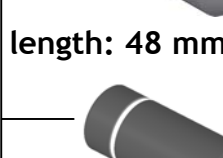
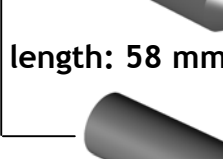
Stud	Head div. length	Part Number Type Diameter	Total length	
			Series I	Series II
 <p>The <b>QuickPlates</b> have fixed studs which can be modified by the use of different heads - perfect variability when <b>balancing</b>. With this system it is possible to fix every kind of rims without any problem on the wheel balancer.</p> <p>Due to the different heads, the studs are available in three different lengths (70 mm / 80 mm / 90 mm / 100 mm)</p> <p>The following heads are available:</p> <ul style="list-style-type: none"> <li>- Short taper</li> <li>- Round head</li> <li>- Range-/ Landrover</li> <li>- Long taper</li> </ul> <p>in different lengths (see right side)</p> <p>Further heads will come soon !</p>	 <p>length: 28 mm</p>	273e008 002 Short taper Ø 24,5 mm	80 mm	70 mm
	 <p>length: 38 mm</p>	273e008 003 Short taper Ø 24,5 mm	90 mm	80 mm
	 <p>length: 48 mm</p>	273e008 004 Short taper Ø 24,5 mm	100 mm	90 mm
	 <p>length: 38 mm</p>	273e008 006 Round head Ø 24,5 mm	90 mm	80 mm
	 <p>length: 48 mm</p>	273e 008 007 Round head Ø 24,5 mm	100 mm	90 mm
	 <p>length: 28 mm</p>	273e008 008 Range-/ Landrover Ø 34,0 mm	80 mm	70 mm
	 <p>length: 48 mm</p>	273e008 011 Long taper Ø 22,5 mm	100 mm	90 mm
	 <p>length: 58 mm</p>	273e008 025 Long taper Ø 22,5 mm	/	100 mm
	 <p>length: 55,6 mm</p>	273e008 023 Long taper Ø 19,0 mm	/	100 mm